

LUTRON QED 20 - BOX - REVERSE ROLL

RECOMMENDED FOR APPLICATIONS WHERE OBJECTS, SUCH AS HANDLES OR LEVERS PROTRUDE FROM WINDOW AND MAY INTERFERE WITH SHADE TRAVEL.

REVERSE ROLLING SHADE MUST BE INSTALLED WITH ALUMINUM BOX CASING

MAXIMUM FASCIA LENGTH : 180"

LIGHT GAP WITH INSIDE MOUNT: $\frac{3}{4}$ "

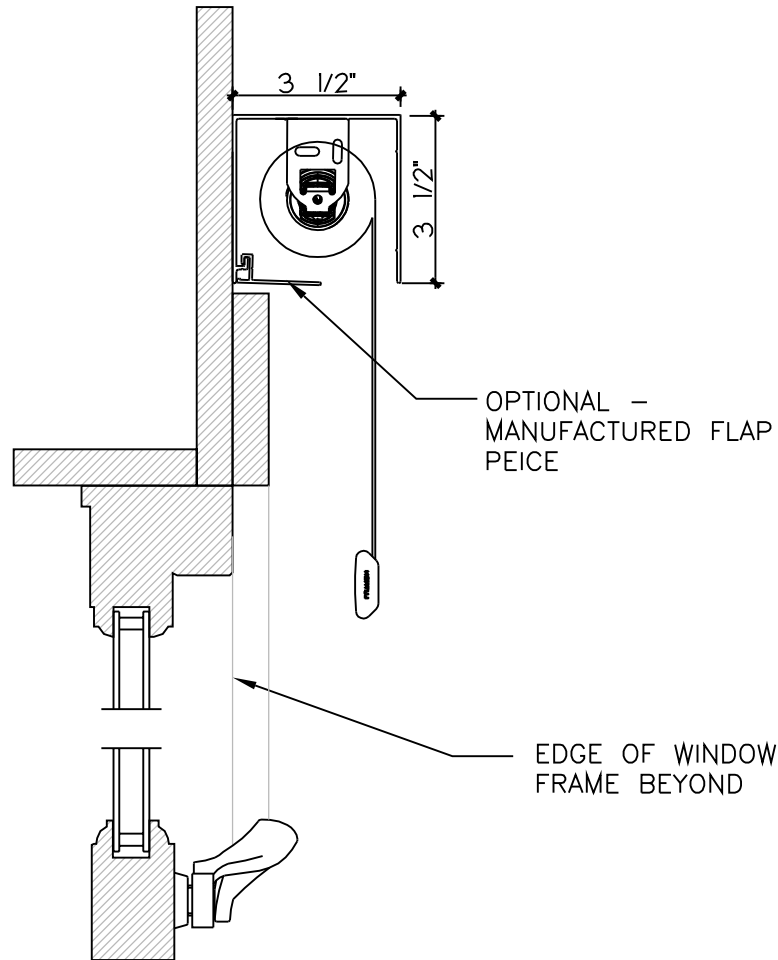

BOX - REVERSE ROLL

SCALE: 3"=1'-0"



THE BOSTON SHADE COMPANY

TITLE:
LUTRON QED 20 BOX - REVERSE ROLL

DATE:08/01/09
SCALE: VARIOUS
DRAWN:EU

SKETCH NUMBER

20.3

THE BOSTON SHADE COMPANY
840 SUMMER STREET SUITE 205,
BOSTON, MA 02127 T. 617.268.7460 F. 617.268.7461